

**Central
Hydraulics®**

MOTORCYCLE LIFT

AIR OPERATED - 1,200 LB. CAPACITY

Model 94813

ASSEMBLY AND OPERATING INSTRUCTIONS



Visit our website at: <http://www.harborfreight.com>



**Read this material before using this product.
Failure to do so can result in serious injury.
SAVE THIS MANUAL.**

Copyright© 2006 by Harbor Freight Tools®. All rights reserved. No portion of this manual or any artwork contained herein may be reproduced in any shape or form without the express written consent of Harbor Freight Tools. Diagrams within this manual may not be drawn proportionally. Due to continuing improvements, actual product may differ slightly from the product described herein. Tools required for assembly and service may not be included.

For technical questions or replacement parts, please call 1-800-444-3353.

Revised Manual 10h; 11a

PRODUCT SPECIFICATIONS

Maximum Lift Capacity	1,200 Pounds
Working Pressure	110 to 125 PSI
Air Hose Inlet Size	1/4"-18 NPT
Valve Operation	Air Activated Pump
Minimum Platform Height	7-5/8"
Maximum Platform Height	33"
Lock Mechanism	Swing-Down Bar (11) Under Platform
Locking Heights	20-1/2" / 23-3/8" / 25-3/8" / 27-1/2" / 29-5/8"
Tire Vise	Opens from 1" to 7" Maximum
Air Hose Dimensions	43-1/2" Long x 1/2" Inner Diameter
Platform Dimensions	78-3/4" Long x 24" Wide
Approach Ramp Dimensions	21" Long x 24" Wide x 1-5/8" High x 13 Gauge Thick
Weight	about 357 lb.
Optional Accessory	Lift Extension Wings (sold separately, Model number 94830)

SAVE THIS MANUAL

You will need this manual for the safety warnings and precautions, assembly, operating, inspection, maintenance and cleaning procedures, parts list and assembly diagram. Keep your invoice with this manual. Write the invoice number on the inside of the front cover. Keep this manual and invoice in a safe and dry place for future reference.

UNPACKING

When unpacking, check to make sure all the parts shown in the **Parts Lists on pages 12 and 14** are included. If any parts are missing or broken, please call Harbor Freight Tools at the number shown on the front cover of this manual as soon as possible.

GENERAL SAFETY RULES

 **WARNING!**

READ AND UNDERSTAND ALL INSTRUCTIONS
Failure to follow all instructions listed below may result in
electric shock, fire, and/or serious injury.
SAVE THESE INSTRUCTIONS

WORK AREA

1. **Keep your work area clean and well lit.** Cluttered and dark work areas invite accidents.
2. **Keep bystanders, children, and visitors away while using the Motorcycle Lift.** Distractions can cause you to lose control.

PERSONAL SAFETY

1. **Stay alert.** Watch what you are doing, and use common sense during use. Do not use the Motorcycle Lift while tired or under the influence of drugs, alcohol, or medication. A moment of inattention while operating equipment may result in serious personal injury.
2. **Dress properly.** Do not wear loose clothing or jewelry. Contain long hair. Keep your hair, clothing, and gloves away from moving parts. Loose clothes, jewelry, or long hair can be caught in moving parts.
3. **Do not overreach.** Keep proper footing and balance at all times. Proper footing and balance enables better control in unexpected situations.
4. **Always wear eye protection.** Wear ANSI-approved safety impact eye glasses when using this product.

TOOL USE AND CARE

1. **Store idle tools and equipment out of reach of children and other untrained people.** Tools and equipment are dangerous in the hands of untrained users.
2. **Maintain the Motorcycle Lift with care.** Keep this product clean. A properly maintained tool is easier to control. Do not use damaged tools and equipment. Tag damaged tools and equipment “**Do not use**” until repaired.
3. **Check for misalignment or binding of moving parts, loose or broken parts, and any other condition that may affect the Motorcycle Lift’s operation.** If damaged, have the tool serviced before using. Many accidents are caused by poorly maintained tools and equipment.
4. **Use only accessories that are recommended by the manufacturer for your model.** Accessories that may be suitable for one product may become hazardous when used on another product.

SERVICE

1. **Tool service must be performed only by qualified service technician.** Service or maintenance performed by unqualified personnel could result in a risk of injury.
2. **When servicing the Motorcycle Lift, use only identical replacement parts.** Follow instructions in the “*Inspection, Maintenance, And Cleaning*” section of this manual. Use of unauthorized parts or failure to follow maintenance instructions may create a risk of injury.

SPECIFIC SAFETY RULES

1. **Maintain labels and nameplates on the Motorcycle Lift.** These carry important information. If unreadable or missing, contact Harbor Freight Tools for a replacement.
2. **Use the right product for the job.** There are certain applications for which this product was designed. Do not use this product for a purpose for which it was not intended.
3. **Industrial applications must follow OSHA requirements.**
4.  **Prior to using this product, make sure to read and understand all instructions and safety precautions as outlined in the motorcycle manufacturer's manual.**
5. **WARNING! Do not exceed the 1,200 pound maximum lifting capacity of this tool.** Exceeding the maximum lifting capacity could cause personal injury and/or property damage. **Beware of dynamic loading!** Suddenly dropping a load onto this product may create, for a brief instant, an excess load which may result in damage to the product and/or personal injury.
6. **Use the Motorcycle Lift only on a flat, level, solid surface capable of supporting the weight of the Lift and the weight of the object being lifted.**
7. **Make sure any load being supported by this Motorcycle Lift is well balanced and centered over the Lift.** Unbalanced loads may cause the lift to tip over, potentially causing serious personal injury and/or property damage.
8. **Stay clear of the Motorcycle Lift when in motion.** Never go under an object being supported by the Lift unless the Safety Bar (11) is in place. **Always use the Safety Bar to lock the Lift when in its up position.**
9. **This Motorcycle Lift is not designed to be used for aircraft purposes.**
10. **Always make sure the object being lifted is properly and safely secured to the Motorcycle Lift prior to raising the object.**
11. **WARNING!** Do not operate a motorcycle in a closed area or a poorly ventilated area. When running, the engine of a motorcycle produces carbon monoxide, a colorless, odorless, toxic fume that, when inhaled, can cause serious personal injury or death.
12. **Always monitor the object being lifted so it does not rock back and forth.**
13. **Never exceed the maximum working air pressure of 125 PSI for this Motorcycle Lift.** Doing so may cause personal injury and/or property damage.

14. **Use compressed air only.** Use clean, dry, regulated, compressed air. Never use oxygen, carbon dioxide, combustible gases, or any other bottled gas as a power source for this tool.
15. **WARNING!** The warnings and cautions discussed in this manual cannot cover all possible conditions and situations that may occur. It must be understood by the operator that common sense and caution are factors which cannot be built into this product, but must be supplied by the operator.

SAVE THESE INSTRUCTIONS

PRE-ASSEMBLY INSTRUCTIONS

NOTE:

For further references to the parts mentioned in the following pages, see the Assembly Diagrams on **pages 13 and 14** of this manual.

To Move The Motorcycle Lift To A Proper Location:

1. A minimum of *two* adults are normally required to set up and operate the Motorcycle Lift.
2. Prepare for assembly by having a clean, spacious, well lit location. It is recommended to assemble the Motorcycle Lift on the floor.

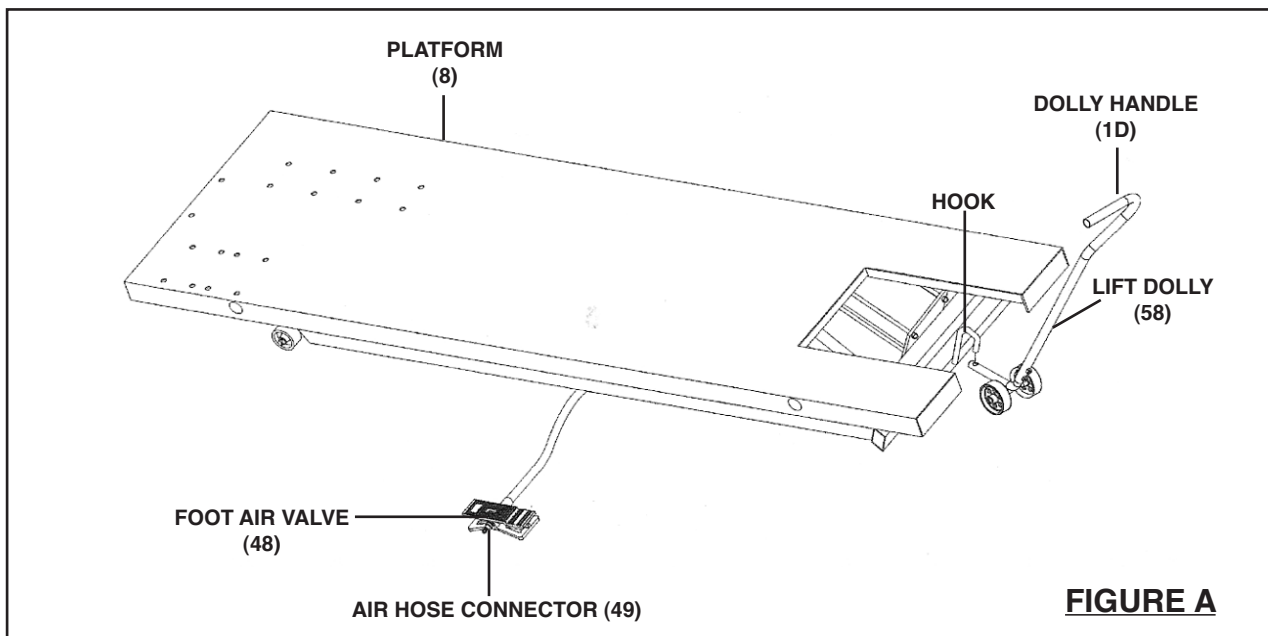

3. Once the Motorcycle Lift is unpacked, use the accessory Lift Dolly (58) to move the Lift to the desired assembly location. To do so, insert the Hook on the Lift's bottom chassis into the hole at the bottom of the Lift Dolly. Press down on the Dolly Handle (1D) to slightly raise the end of the Motorcycle Lift. Then, move the Lift to the desired assembly location. **(See Figure A.)**

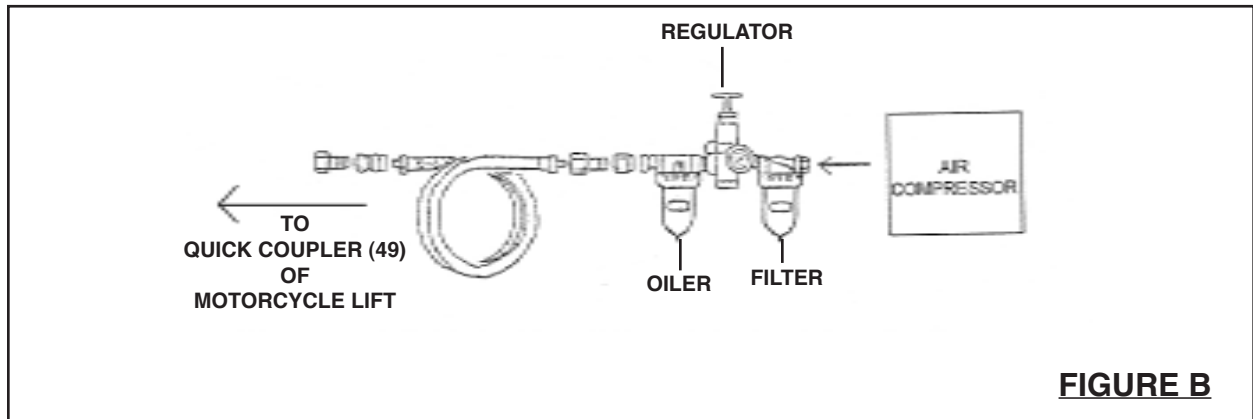

FIGURE B

To Connect The Motorcycle Lift To An Air Compressor:

For best service, you should incorporate an oiler, regulator, and in-line filter, as above. Hoses, couplers, oilers, regulators, and filters are all available at Harbor Freight Tools.

Note: If an automatic oiler is not used, put 3-5 drops of pneumatic Tool Oil (not included) in the Motorcycle Lift's Air Hose Connector (49) before each use. **(See Figure A.)**

ASSEMBLY INSTRUCTIONS

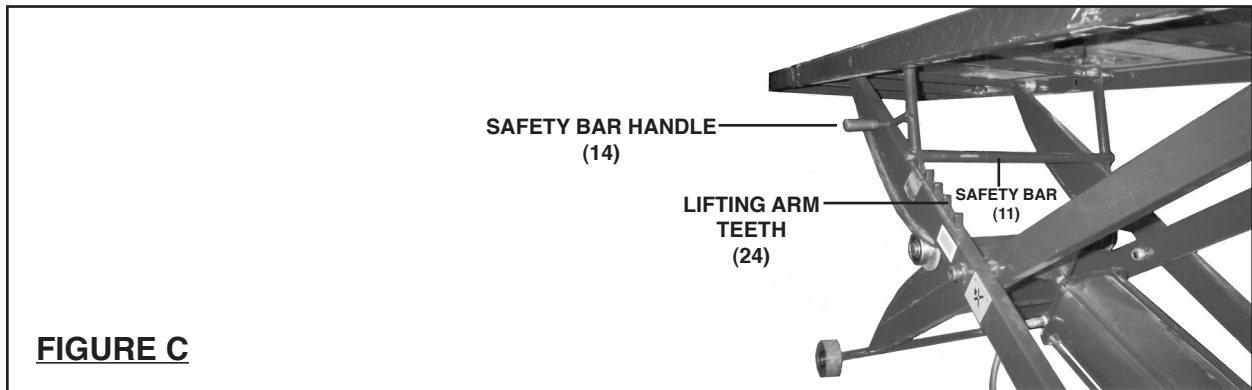

WARNING! As an additional safety precaution, **ALWAYS** lower the Safety Bar (11) completely and make sure it rests between the teeth of the Lifting Arms (24) when the Motorcycle Lift is in its raised position. To do so, raise the Motorcycle Lift to slightly above the desired height. Lower the Safety Bar and, while holding the Safety Bar in its lowered position, slowly lower the Motorcycle Lift until the Safety Bar is firmly settled between the teeth of the Lifting Arms. (See Figure C.)

To Attach The Tire Stop Plate:

1. Step on and hold down the right side of the Foot Air Valve (48) until the Platform (8) of the Motorcycle Lift reaches its maximum height. Then, lower and lock the Safety Bar (11) in position. (See Figures A and C.)

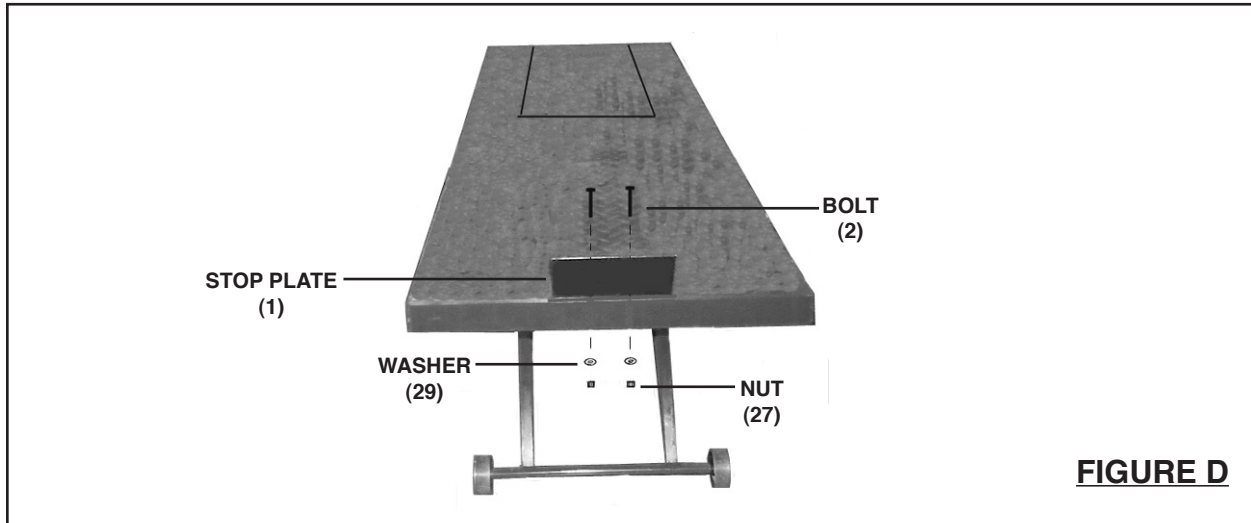

FIGURE D

- Align the two mounting slots in the Stop Plate (1) with the two mounting holes located at the rear of the Platform (8). Then secure the Stop Plate to the Platform, using two Bolts (2), two Washers (29), and two Nuts (27). **NOTE:** When adjusting the Stop Plate forward or backward, make sure to retighten the two Nuts. (See Figure D.)

To Install The Vise Assembly:

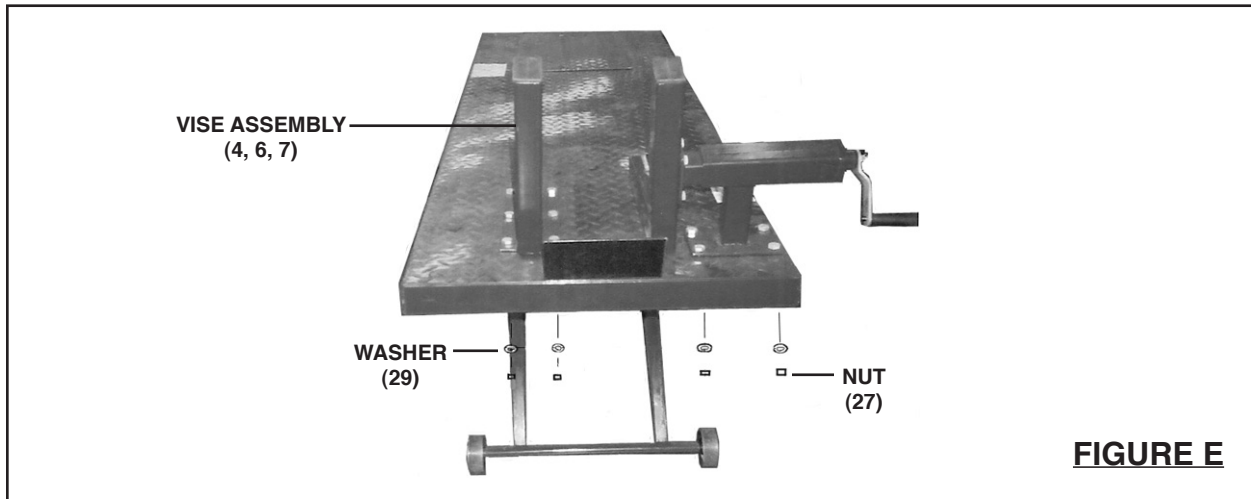
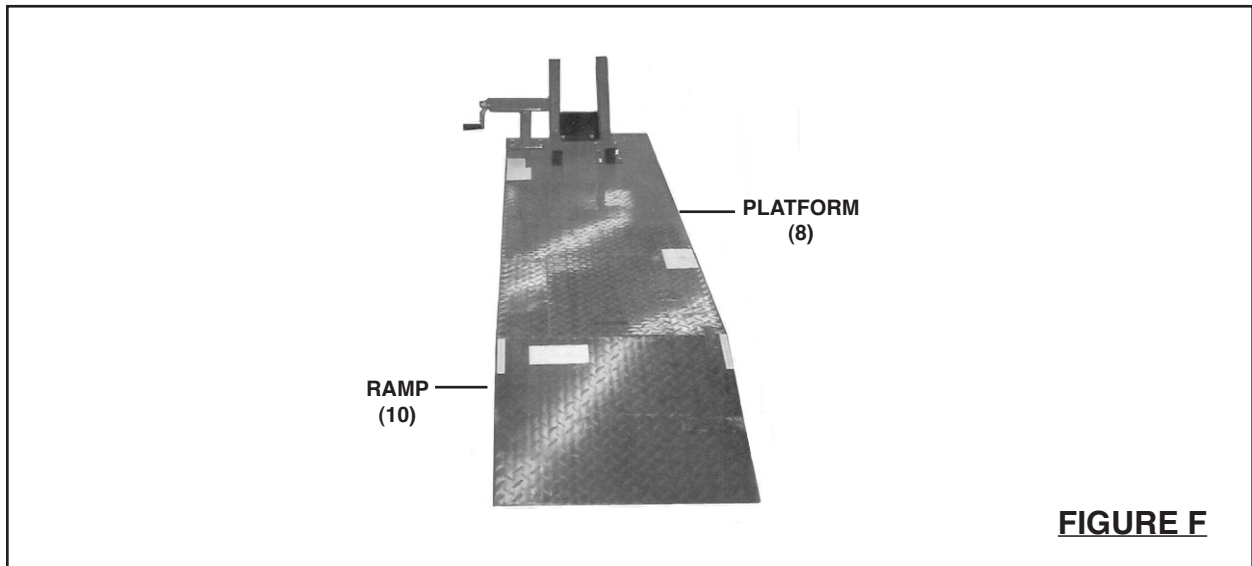

FIGURE E

- NOTE:** Additional mounting holes at the rear of the Platform (8) allow for adjusting the forward/backward location of the Vise assembly. (See Figure E.)
- To install the Vise Assembly (4, 6, 7), align the ten mounting holes at the base of the Vise Assembly with ten of the mounting holes located at the rear of the Platform (8). Then secure the Vise assembly to the Platform, using ten Bolts (2), Washers (29), and Nuts (27). (See Figure E.)

To Install The Ramp:



With assistance, lift the Ramp (10) and insert its two prongs into the two mounting holes located at the front of the Platform. **(See Figure F.)**

OPERATING INSTRUCTIONS

1. **WARNING! Do not exceed the maximum lifting capacity of this tool (1,200 pounds).** Exceeding the maximum lifting capacities could cause personal injury and/or property damage.
2. Make sure the Platform (8) is fully collapsed to the floor. Also, make sure the Removable Plate (9) is properly positioned over the inspection hole of the Platform (8).
3. With assistance, roll the motorcycle up the Ramp (10) and onto the Platform (8) until its front wheel contacts the Stop Plate (1). Then, kick the center stand of the motorcycle down to stabilize it on the Lift.
4. Adjust the Vise assembly (4, 6, 7), and clamp the bottom of the front motorcycle wheel into the Vise assembly. Then, resecure the Vise assembly to the Platform (8). You should also stabilize the motorcycle using tie-down straps (not included) on each side of the motorcycle with one end of the straps tied to the motorcycle and the other end of the straps tied to the Platform (8).
5. Connect the air compressor's hose to the Foot Valve Air. Then turn on the air compressor and set its regulator to 110 to 125 PSI. Do not exceed 125 PSI. (See Figure B.) Make sure the Foot Air Valve (48) is located on the floor surface and safely away from the Motorcycle Lift so as to avoid damaging the Foot Air Valve. (See Figure A.) Step on and hold down the right side of the Foot Air Valve (48) until the Platform (8) of the Motorcycle Lift reaches its maximum height. Then step on and hold the left side of the Foot Air Valve until the Platform is fully collapsed to the floor. Repeat this procedure several times to ensure the Motorcycle Lift is operating properly. (See Figure A.)
6. When the Platform (8) has been raised to the working height, lower the Safety Bar (11) completely to prevent the Motorcycle Lift from accidentally lowering.
7. When work on the motorcycle is completed, check under the Motorcycle Lift to make sure there are no tools, motorcycle parts, etc. and that it is safe to lower the Lift.
8. Swing the Safety Bar (11) aside. Then step on and hold down the left side of the Foot Air Valve (48) to *slowly* lower the Platform (8) to the floor.
9. With assistance, remove the tie-down straps from the motorcycle. Loosen the Vise assembly (4, 6, 7). Kick the center stand of the motorcycle up. Then, slowly back the motorcycle completely off the Motorcycle Lift.
10. Turn off the air compressor. Step on and hold down the left side of the Foot Air Valve (48) to release any remaining compressed air in the system. Then, disconnect the compressor's air hose from the Foot Air Valve.
11. Make sure to store the Motorcycle Lift in a clean, dry, safe location out of reach of children and other unauthorized people.

INSPECTION, MAINTENANCE, AND CLEANING

1. **Before each use:** Inspect the general condition of the Motorcycle Lift. Check for cracked, worn or damaged parts, loose or missing parts, low or no hydraulic oil, and any other condition that may affect the tool's safe operation. If a problem occurs, have the problem corrected before further use.
Do not use damaged equipment.
2. **To clean:** Use a damp cloth and a mild detergent. Do not use solvents or other flammable agents.
3. **When storing:** Keep the Motorcycle Lift and its accessories in a clean, dry, safe location out of reach of children and other unauthorized people.
4. **CAUTION!** All maintenance, service, and repairs not discussed in this manual should only be performed by a qualified service technician.

TROUBLESHOOTING

Problem	Possible Solution
Motorcycle Lift "fades", allowing a load to slowly lower on its own.	<ol style="list-style-type: none">1. Make sure the unit's 1,200 pound lifting capacity is not being exceeded.2. Check all air connections for leaks.3. The Air Foot Valve (48) may be leaking. A technician should investigate and replace o-rings or entire unit as necessary.4. If none of the above solutions correct the problem, have a qualified service technician examine the unit. Do not use the unit until completely repaired.

PLEASE READ THE FOLLOWING CAREFULLY

THE MANUFACTURER AND/OR DISTRIBUTOR HAS PROVIDED THE PARTS LIST AND ASSEMBLY DIAGRAM IN THIS MANUAL AS A REFERENCE TOOL ONLY. NEITHER THE MANUFACTURER OR DISTRIBUTOR MAKES ANY REPRESENTATION OR WARRANTY OF ANY KIND TO THE BUYER THAT HE OR SHE IS QUALIFIED TO REPLACE ANY PARTS OF THE PRODUCT. IN FACT, THE MANUFACTURER AND/OR DISTRIBUTOR EXPRESSLY STATES THAT ALL REPAIRS AND PARTS REPLACEMENTS SHOULD BE UNDERTAKEN BY CERTIFIED AND LICENSED TECHNICIANS, AND NOT BY THE BUYER. THE BUYER ASSUMES ALL RISKS AND LIABILITY ARISING OUT OF HIS OR HER REPAIRS TO THE ORIGINAL PRODUCT OR REPLACEMENT PARTS THERETO, OR ARISING OUT OF HIS OR HER INSTALLATION OF REPLACEMENT PARTS THERETO.

MAIN PARTS LIST

Part	Description	Qty.
1	Stop Plate	1
2	Bolt (M10 x 25)	12
4	Adjustable Shelf M10 x 25	1
5	Bolt (M8 x 20)	4
6	Moveable Vise Assy.	1
7	Stationary Vise Assy.	1
8	Platform	1
9	Removable Plate	1
10	Ramp	1
11	Safety Bar	1
12	Clevis Pin	2
13	R-Pin	2
14	Safety Bar Handle	1
15	Bolt (M16 x 130)	2
16	Washer (#16)	6
17	Lock Nut (M16)	4
18	Lifting Arm	1
19	Bolt (M16 x 80)	2
22	Retaining Ring	4
23	Frame/Cylinder Pivot Shaft	1
24	Lifting Arm	1
25	Cylinder End Plate	1
26	Lock Nut (M10)	2
27	Nut (M10)	16
28	Lock Washer (#10)	20
29	Washer (#10)	20
30a	Stay Bolt	4
31a	Cylinder	1
33a	Piston	1
34a	O-Ring	1
35	O-Ring	1
36	Seal Ring	1
37a	Press Ring	1
38a	Retaining Ring	2
39a	Piston Rod	1
40a	O-Ring	2
41a	Shaft Bushing	1
43a	O-Ring	1
45a	Front Cover	1
46a	Nut	1

Part	Description	Qty.
47	Air Hose	1
48*	Foot Operated Air Valve	1
49	Air Hose Connector	1
51	Wheel	2
52	Connection	1
53	Bolt (M10 x 45)	2
54	Cam Bearing Spacer	4
56	Roller	2
57	Roller	2
58*	Lift Dolly	1
59	Grease fitting	4
60	Cotter Pin	2
61	Air Pump Washer	2
62	Bolt (M12 x 25)	1
63	Washer (#12)	1
64	O-Ring	1
65	Retaining Ring	4
66	Cam Bearing Spacer	4
67	Retaining Ring	2
68	Split Washer	1
69	O-Ring	2
70	Connector	1
71	Connecting Block	1
72	Filter Base	1
73	Filter	1
74	O-Ring	1
75	Connecting Bolt	1
76	Mut (M10)	4

* See the additional Parts List and Assembly Diagram on page 14.

NOTE:

Some parts are listed and shown for illustration purposes only,
and are not available individually as replacement parts.

REV 10h

MAIN ASSEMBLY DIAGRAM

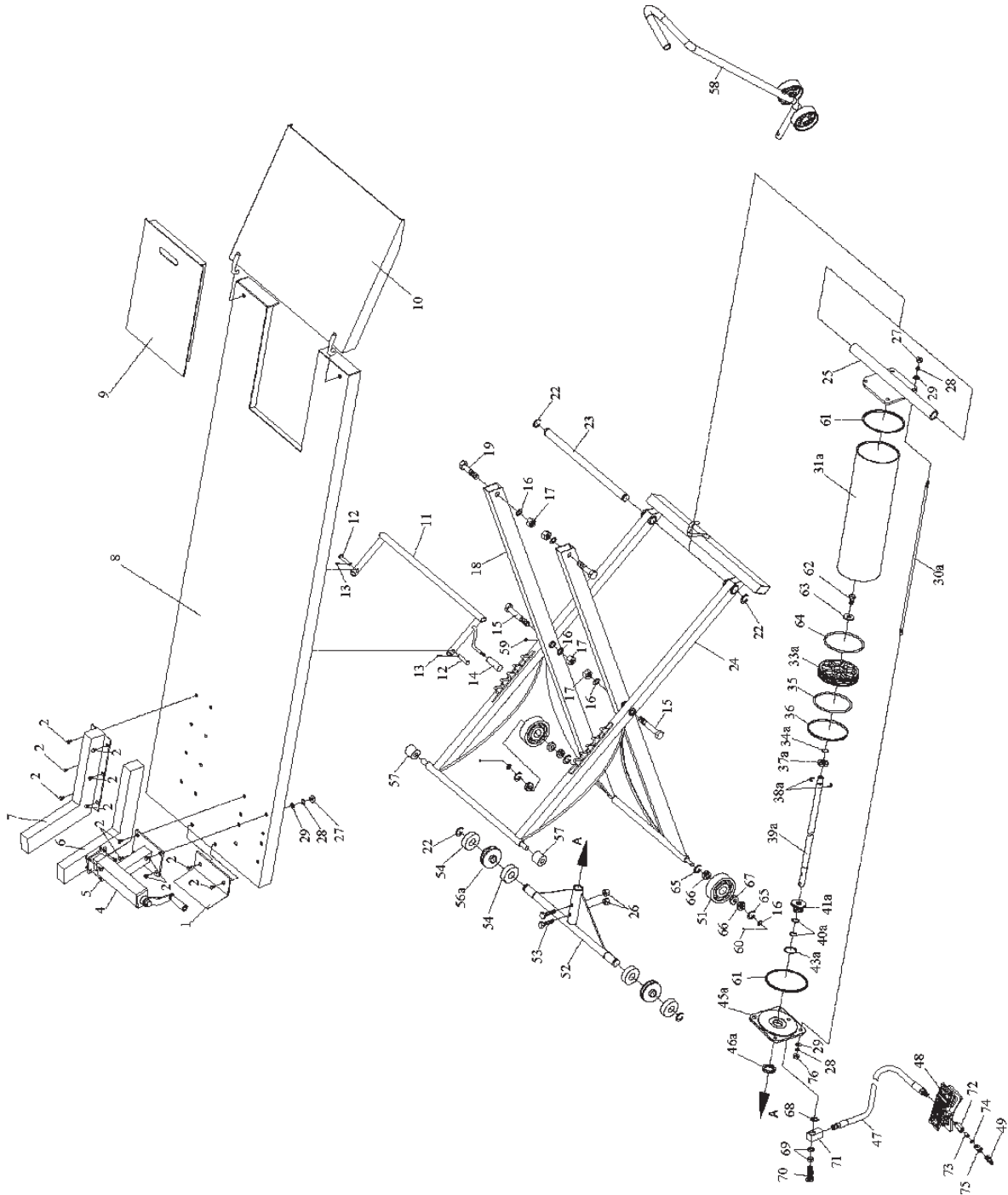

NOTE:

Some parts are listed and shown for illustration purposes only, and are not available individually as replacement parts.

REV 10h

PARTS LIST AND ASSEMBLY DIAGRAM - LIFT DOLLY (58)

Part	Description	Qty
1D	Dolly Handle	1
2D	Bolt	2
3D	Pin	2
4D	Washer	2
5D	Nut	2
6D	Wheel	2
7D	Dolly Set	1

NOTE:
Some parts are listed and shown for illustration purposes only, and are not available individually as replacement parts.

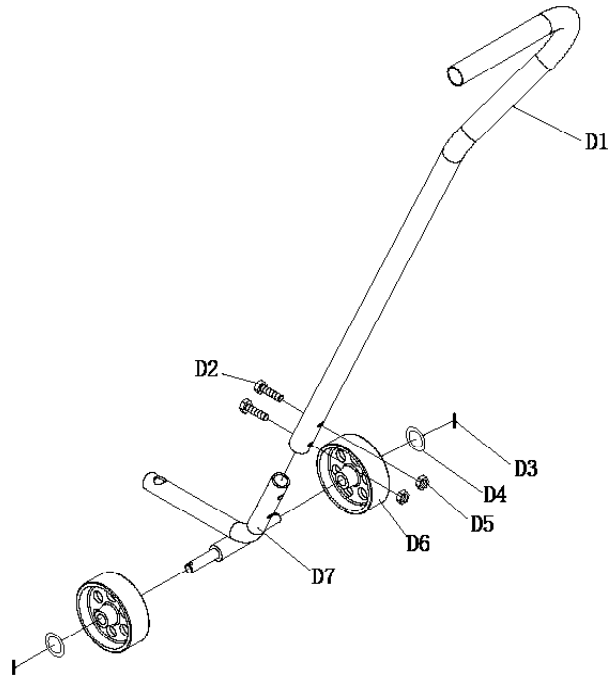

PARTS LIST AND ASSEMBLY DIAGRAM - FOOT AIR VALVE (48)

Part	Description	Qty
1V	Foot Pedal	1
2V	Retaining Ring	1
3V	Washer	2
4V	O-Ring	1
5V	Valve Rod	1
6V	O-Ring	2
7V	Seal	1
8V	Retaining Ring	1
9V	Lock Nut	1
10V	Valve Body	1
11V	Bolt	1
12V	Quick Coupler	1

NOTE:
Some parts are listed and shown for illustration purposes only, and are not available individually as replacement parts.

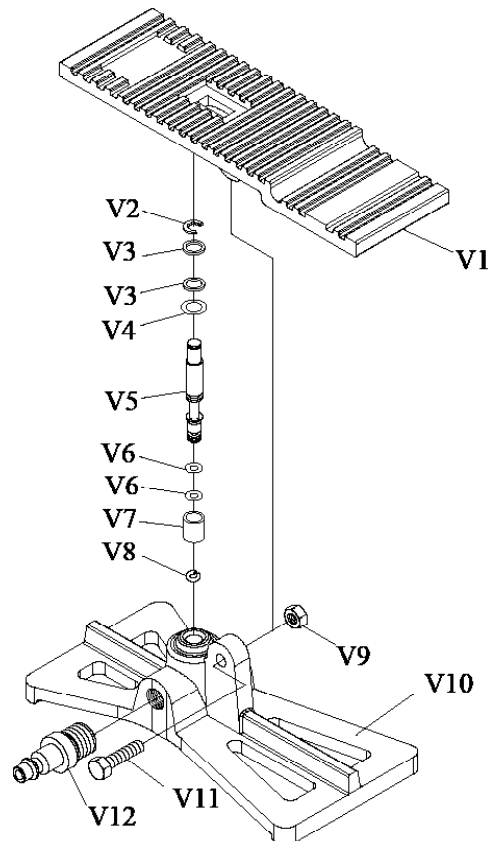

REV 10h

LIMITED 90 DAY WARRANTY

Harbor Freight Tools Co. makes every effort to assure that its products meet high quality and durability standards, and warrants to the original purchaser that this product is free from defects in materials and workmanship for the period of 90 days from the date of purchase. This warranty does not apply to damage due directly or indirectly, to misuse, abuse, negligence or accidents, repairs or alterations outside our facilities, criminal activity, improper installation, normal wear and tear, or to lack of maintenance. We shall in no event be liable for death, injuries to persons or property, or for incidental, contingent, special or consequential damages arising from the use of our product. Some states do not allow the exclusion or limitation of incidental or consequential damages, so the above limitation of exclusion may not apply to you. THIS WARRANTY IS EXPRESSLY IN LIEU OF ALL OTHER WARRANTIES, EXPRESS OR IMPLIED, INCLUDING THE WARRANTIES OF MERCHANTABILITY AND FITNESS.

To take advantage of this warranty, the product or part must be returned to us with transportation charges prepaid. Proof of purchase date and an explanation of the complaint must accompany the merchandise. If our inspection verifies the defect, we will either repair or replace the product at our election or we may elect to refund the purchase price if we cannot readily and quickly provide you with a replacement. We will return repaired products at our expense, but if we determine there is no defect, or that the defect resulted from causes not within the scope of our warranty, then you must bear the cost of returning the product.

This warranty gives you specific legal rights and you may also have other rights which vary from state to state.

3491 Mission Oaks Blvd. • PO Box 6009 • Camarillo, CA 93011 • (800) 444-3353